



SINCE 1973

Leak-Proof
Engineering

Mechanical Seal API Piping Plans

POCKET GUIDE

API PIPING PLAN INTRODUCTION

FLUSH PLANS

LIQUID BARRIER/BUFFER PLANS

GAS BARRIER/BUFFER PLANS

QUENCH PLANS

COLLECTION PLANS

SPECIAL PLANS

USEFUL INFORMATION

INTRODUCTION

A crucial element in attaining highly reliable and effective sealing performance is establishment of an optimal fluid environment surrounding the seal. The selection of an appropriate piping configuration and the corresponding fluid control apparatus necessitates a comprehensive understanding of the seal design and arrangement, the fluids in which they function, and the rotating machinery to which they are attached. Key considerations include the provision of clean and cool lubrication for the seal faces, efficient heat dissipation, and the prioritization of personnel and environmental safety, as well as leakage management and cost control of the system. The American Petroleum Institute (API) has developed standardized piping plans for seals, offering industry guidelines for various seal configurations, fluids, and control equipment. The accompanying illustrations are derived from API 682.

The subsequent pages depict and explain the characteristics of these plans, serving as a resource to identify the support system requirements that will enhance the performance reliability of your fluid-handling rotating equipment applications.

DISCLAIMER: This booklet is provided for guidance only and must not be used for engineering purpose. It aims to showcase the common connections employed across various piping plans, irrespective of the equipment type, thus utilizing generic terminology for the connections.

API PIPING PLAN

CLASSIFICATION

Flush Plans	Clean liquid is introduced into the seal chamber near the seal faces. These plans are typically used for cooling, cleaning and lubricating the seal faces purposes.
Liquid Barrier Buffer Plans	Fluid is introduced in between the inboard and outboard seals. These plans are categorically used in Double Mechanical Seals for the purpose of cooling, cleaning and lubricating the seal faces.
Gas Barrier Buffer Plans	
Quench Plans	Neutral fluid, usually steam, gas or water, is introduced on the atmospheric side of the seal to remove the formation of solids that may interfere with seal operation.
Collection Plans	Seal leakage is collected either in a reservoir or in a cavity. These plans usually comes with an alarm to detect excessive leakage.

Barrier Plan: Plan fluid pressure is higher than process fluid pressure.

Buffer Plan: Plan fluid pressure is lower than process fluid pressure.

FLUSH PLAN

- Plan 01** Single Seals / Double Seals (Inboard) – Internal flush
- Plan 02** Single Seals / Double Seals (Inboard) – No flush
- Plan 03** Single Seals / Double Seals (Inboard) – Circulation between seal chamber and pump created by the design of the seal chamber
 - Plan 11** Single Seals / Double Seals (Inboard) – Recirculation from discharge with orifice
 - Plan 12** Single Seals / Double Seals (Inboard) – Recirculation from discharge with strainer & orifice
 - Plan 13** Single Seals / Double Seals (Inboard) – Recirculation from the seal chamber through an orifice to suction
 - Plan 14** Single Seals / Double Seals (Inboard) – Recirculation from discharge through seal chamber back to suction
 - Plan 21** Single Seals / Double Seals (Inboard) – Recirculation from discharge through orifice & heat exchanger
 - Plan 22** Single Seals / Double Seals (Inboard) – Recirculation discharge through a strainer, orifice & heat exchanger

API PIPING PLAN

- Plan 23** Single Seals / Double Seals (Inboard) - Closed loop recirculation by pumping ring through a heat exchanger back to seal the chamber
- Plan 31** Single Seals / Double Seals (Inboard) - By-pass from discharge through abrasive separator
- Plan 32** Single Seals / Double Seals (Inboard) - External flush source to seal
- Plan 41** Single Seals / Double Seals (Inboard) - By-pass from discharge through abrasive separator & heat exchanger

LIQUID BARRIER / BUFFER PLAN

- Plan 52** Double Seals, unpressurized – External reservoir unpressurized liquid buffer
- Plan 53A** Double Seals, pressurized – External reservoir pressurized liquid barrier
- Plan 53B** Double Seals, pressurized – Liquid barrier through heat exchanger & pressurized by accumulator
- Plan 53C** Double Seals, pressurized – Liquid barrier through heat exchanger with differential pressure tracking piston
- Plan 54** Double Seals, pressurized – External pressurized barrier system/source
- Plan 55** Double Seals, unpressurized – External, unpressurized buffer system/source

GAS BARRIER / BUFFER PLAN

- Plan 71** Secondary containment seals – Tap connection for purchasers use
- Plan 72** Secondary containment seals – Low pressure buffer gas injected to outer seal cavity
- Plan 74** Double gas seals – Pressurized barrier gas system for Double gas seals

QUENCH PLAN

- Plan 51** Single Seals / Double Seals (Inboard) – Dead-ended atmospheric quench
- Plan 61** Quench seals – Quench connection for purchasers use
- Plan 62** Quench seals – External quench on atmospheric side of seal

COLLECTION PLAN

- Plan 65A** Single seals – Atmospheric leakage collection/detection for condensing leakage with failure detection by excess flow into system



















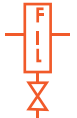







API PIPING PLAN

- Plan 65B** Single seals – Atmospheric leakage collection/detection for condensing leakage with failure detection by cumulative leakage into system
- Plan 66A** Single seals – External leakage detection arrangement with throttle bushings
- Plan 66B** Single seals – External leakage detection arrangement with orifice plug
- Plan 75** Secondary containment seals – Leakage collection system for condensing or mixed phase leakage
- Plan 76** Secondary containment seals – Secondary containment seal vented to flare or collection system

SPECIAL PLAN

- Plan 99** Single seals, Double Seals, quench seals, secondary containment seals & Double gas seals – Defines an engineered piping plan not defined by any existing plans

API PIPING SYMBOLS

	ORIFICE		STRAINER		PRESSURE INDICATOR		LEVEL TRANSMITTER WITH LOCAL INDICATOR
	BLOCK VALVE		HEAT EXCHANGER		TEMPERATURE INDICATOR		FLOW TRANSMITTER WITH LOCAL INDICATOR
	CHECK VALVE		COALESCING FILTER		LEVEL INDICATOR		PRESSURE SWITCH LOW
	FLOW REGULATING VALVE		RESERVOIR		FLOW INDICATOR		LEVEL SWITCH HIGH
	PRESSURE CONTROL VALVE		PISTON ACCUMULATOR		FLOW METER		LEVEL SWITCH LOW
	PRESSURE RELIEF VALVE		BLADDER ACCUMULATOR		PRESSURE TRANSMITTER WITH LOCAL INDICATOR		FLOW SWITCH HIGH
	CYCLONE SEPARATOR				DIFFERENTIAL PRESSURE TRANSMITTER WITH LOCAL INDICATOR	HAL	HIGH LEVEL ALARM SET POINT
					TEMPERATURE WITH LOCAL INDICATOR	LLA	LOW LEVEL ALARM SET POINT
						NLA	NORMAL LIQUID LEVEL

BEST PIPING PRACTICES

- ◆ Minimize piping line losses.
- ◆ Use large radius bends.
- ◆ Tangential outlet ports.
- ◆ Verify shaft rotation direction.
- ◆ Slope horizontal runs upward (40 mm/m (1/2 in/ft)).
- ◆ Install drain at lowest piping point.
- ◆ Flush is recommended whenever possible.
- ◆ Use forced circulation where possible.
- ◆ Cooling is recommended for buffer/barrier fluid.
- ◆ Always properly vent the system prior to start-up.
- ◆ Always verify pressure and/or level switch set points.
- ◆ Check system for leaks.
- ◆ Check compatibility of buffer/barrier fluid with the end product.
- ◆ Long radius bends shall be used to minimize friction losses and elbows should be avoided.
- ◆ Elbows shown in sketches are for illustrative purpose only.
- ◆ Use 20mm ($\frac{3}{4}$ ") interconnecting piping/tubing for plans where flow is produced by an internal circulation device (pumping ring or scroll).
- ◆ Use 12mm ($\frac{1}{2}$ ") interconnecting piping/tubing for plans where flow is produced by pump differential pressures.

PLAN 01 | Single Seal – Internal Flush

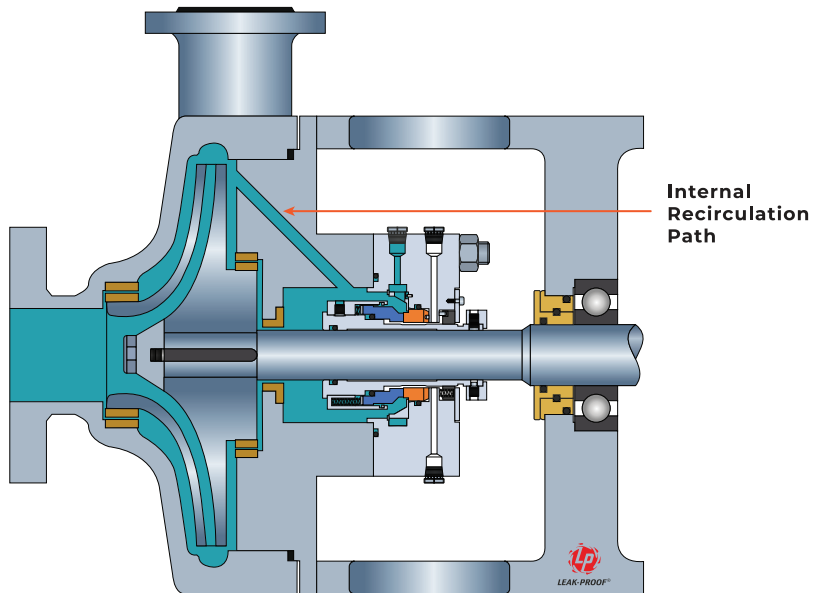

FLUSH PLAN - SINGLE SEALS / DOUBLE SEALS (INBOARD) PLAN 01

Description

Plan 01 is an integrated (internal) recirculation of the product from the pump discharge into the seal chamber. The flush port is plugged in for possible future use.

Features

1. Provides flush to remove heat from the seal chamber without the need for an external piping plan.
2. Since flush is not exposed to the atmosphere, the risk of freezing/polymerizing highly viscous fluids at lower temperatures is reduced.

Application

1. Used in clean fluids and the fluids tend to thicken, solidify or polymerize on atmospheric exposure.
2. Used for horizontal pumps.

Precautions

1. Ensure the flow of flush fluid recirculation is enough for seal heat removal.
2. If used in dirty products, it can clog the flush line.
3. Not recommended for vertical pumps.

PLAN 02 | Single Seal – No Flush

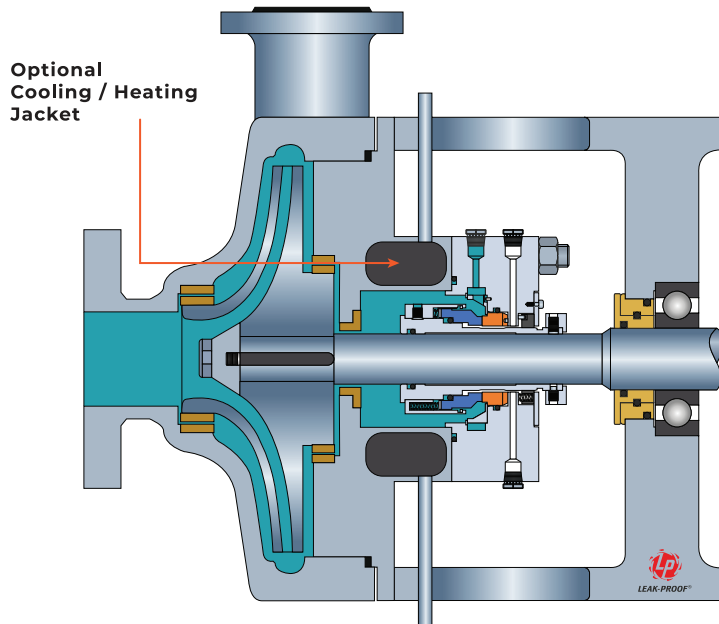

FLUSH PLAN - SINGLE SEALS / DOUBLE SEALS (INBOARD) PLAN 02

Description

Plan 02 is a non-circulating flush fluid with a dead-ended seal chamber plan. The flush port is plugged in for possible future use.

Features

1. Carries a jacketed seal chamber to remove heat from the seal chamber without needing an external piping plan.
2. Since flush circulation is not present the fluid solids are not continually introduced into the seal chamber.

Application

1. Used in large bore seal chamber pumps with a cooling jacket.
2. Used for low-speed pumps.

Precautions

1. Consider the vapor pressure margin in the seal chamber to avoid flashing by the temperature rise of process fluid due to seal face heat generation.
2. Ensure the vent is on top when used with horizontal pumps with cylindrical chambers.
3. Do not use without a cooling/heating jacket.
4. Ensure regular cleaning and maintenance of the cooling jacket on time as fouling can affect the cooling efficiency.

PLAN 03 | Single Seal – Seal Chamber Circulation

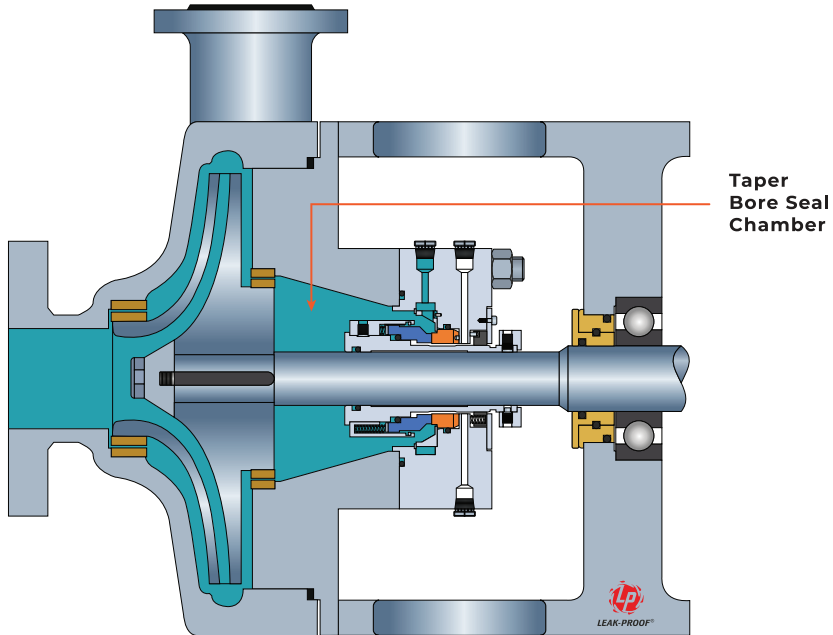

FLUSH PLAN - SINGLE SEALS / DOUBLE SEALS (INBOARD) PLAN 03

Description

Plan 03 is a product circulation between the seal chamber and the pump created by the design of the seal chamber. Flush connections are plugged in.

Features

1. Seal face heat generation is removed by product flow created by seal chamber design without needing an external piping plan.
2. The tapered seal chamber design helps improve air or vapor venting.

Application

1. Used in pumps with a taper bore seal chamber and no throat bushing.
2. When there is no significant seal face heat generation.
3. To reduce chances of solid contamination unlike in traditional cylindrical seal chambers.

Precautions

1. Should not be used with cylindrical bore seal chamber.
2. May not be suitable for high temperature and high-pressure applications.

PLAN 11 | Flush Plan – By-pass from Discharge

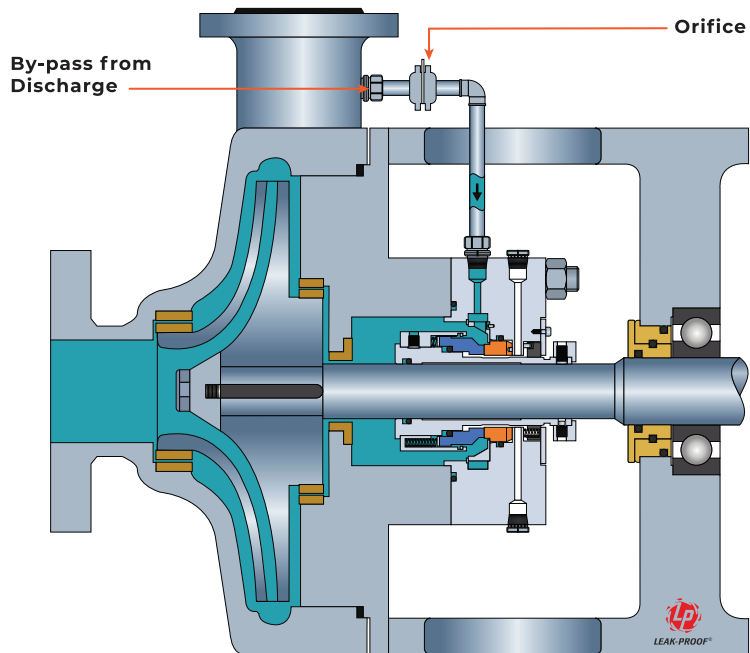

FLUSH PLAN - SINGLE SEALS / DOUBLE SEALS (INBOARD) PLAN 11

Description

Plan 11 is flush plan with product circulation from the pump discharge through a flow control orifice to the seal chamber for seal faces cooling and lubrication.

Features

1. Additional positive pressure maintaining for product circulation helps in increasing vapour pressure margin.
2. The flushing as well as self-venting feature of this plan in horizontal pump makes it most preferable among single and double inboard mechanical seals.

Application

1. Application with clean and non-polymerizing fluids with moderate temperature.

Precautions

1. Ensure that the difference between pump discharge and the seal chamber pressure is enough to achieve required flow rate.
2. Not recommended with product containing solids and abrasive particles.
3. Orifice size should be at least 3mm (1/8").

PLAN 12 | Flush Plan – By-pass from Discharge with Strainer

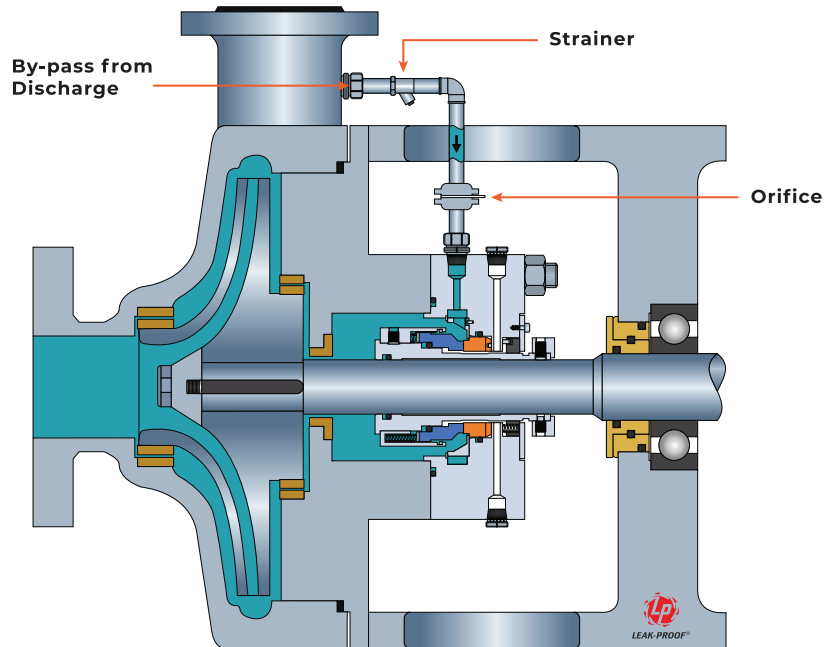

FLUSH PLAN - SINGLE SEALS / DOUBLE SEALS (INBOARD) PLAN 12

Description

Plan 12 is a (Plan11 + Strainer) flush plan with product circulation from the pump discharge through a strainer and flow control orifice to the seal chamber for seal faces cooling and lubrication.

Features

1. In addition to plan 11 features, it can handle dirty products up to certain extent.

Application

1. Application with slightly contaminated (fluids with suspended solids) and non-polymerizing fluids with moderate temperature.

Precautions

1. Always ensure that the strainer is placed first before orifice in the direction of flow.
2. Not recommended due to strainer unreliability and also not proven to achieve a 3-year operating life.
3. Recommended to use with differential pressure indicator or alarm to know the strainer clogging status and avoid seal failure.

PLAN 13 | Flush Plan – Flush from Seal Chamber to Suction

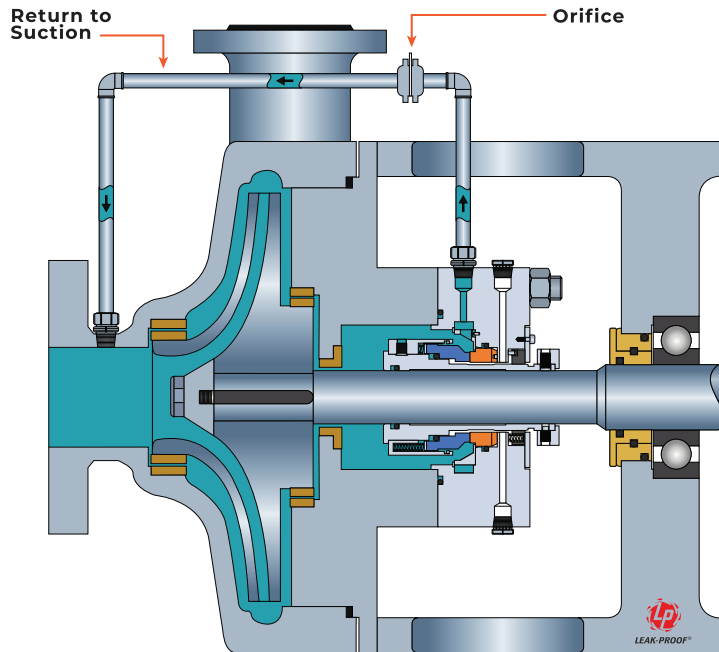

FLUSH PLAN - SINGLE SEALS / DOUBLE SEALS (INBOARD) PLAN 13

Description

Plan 13 is a flush plan with product recirculation from seal chamber to the pump suction through a flow control orifice for seal faces cooling and lubrication.

Features

1. Provides continuous vent for vertical pumps.
2. Seal chamber pressure can be controlled with proper sizing of the orifice and the bushing clearance.

Application

1. Used when there is no enough pressure margin between pump discharge and seal chamber pressure.
2. Typically used in vertical pumps.

Precautions

1. Plan 13 is not as efficient as Plan 11 in removing seal face generated heat because of difference in flow patterns and thus require a higher flow rate.
2. A distributed flush is not recommended with plan 13.

PLAN 14 | Flush Plan - By-pass from Discharge to Seal Chamber and back to Suction

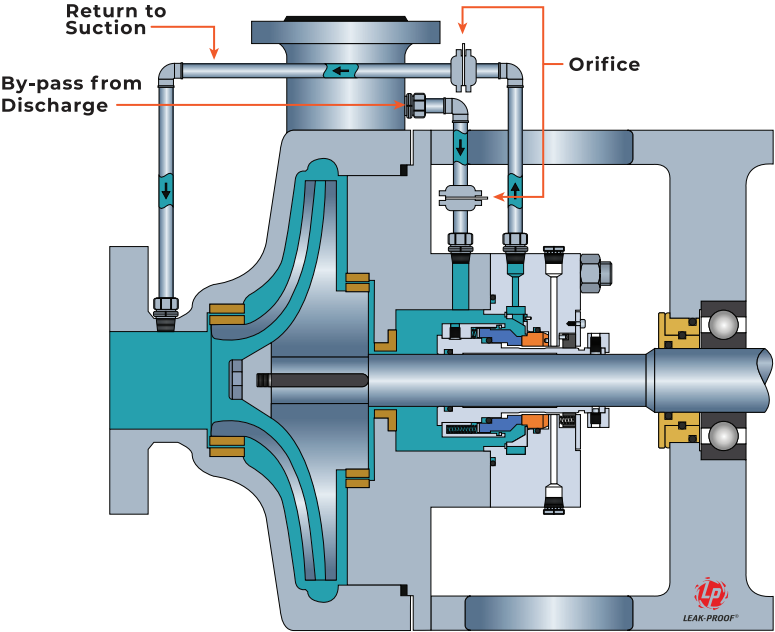

FLUSH PLAN - SINGLE SEALS / DOUBLE SEALS (INBOARD) PLAN 14

Description

Plan 14 is a (Plan 11 + Plan 13) flush plan with product recirculation from pump discharge through flow control orifice to the seal chamber and sent back from seal chamber to the pump suction through a flow control orifice for seal faces cooling and lubrication.

Features

1. Provides product recirculation as well as venting.
2. Seal face cooling is optimized with adequate flow rate.
3. Provides adequate vapor pressure margin.

Application

1. Used in vertical pumps.

Precautions

1. A distributed flush is not recommended with plan 13.
2. Check for enough pressure margin between pump discharge and seal chamber pressure also between the seal chamber and pump suction pressure.

PLAN 21 | Flush Plan – By-pass from Discharge through Heat Exchanger

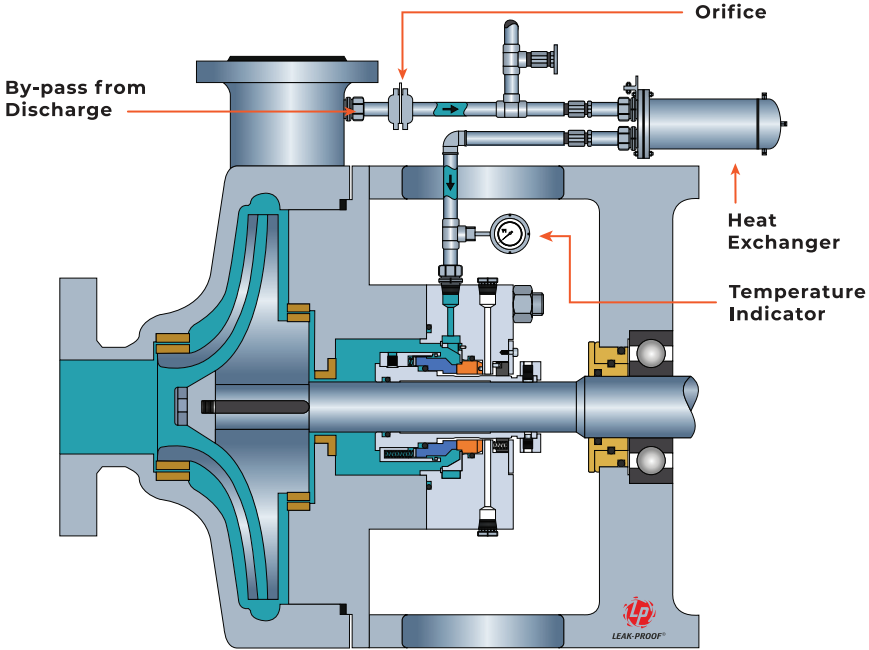

FLUSH PLAN - SINGLE SEALS / DOUBLE SEALS (INBOARD) PLAN 21

Description

Plan 21 is a (Plan 11 + Heat exchanger) flush plan with product circulation from the pump discharge through a flow control orifice and heat exchanger to the seal chamber for seal faces cooling and lubrication.

Features

1. Along with vapour pressure margin the temperature margin is also improved to meet secondary sealing element temperature limits and avoid vapor formation.
2. Helps to reduce coking and improve lubricity.

Application

1. High temperature application e.g., Hot water (Temp > 80°C), hot hydrocarbons & hot non-polymerizing fluids.

Precautions

1. Always ensure that the heat exchanger is placed after the orifice in the direction of flow.
2. High cooler duty tends to fouling on waterside.
3. Possibility of plugging on process side if the product viscosity rises quickly.

PLAN 22 | Flush Plan – By-pass from Discharge with Strainer through Heat Exchanger

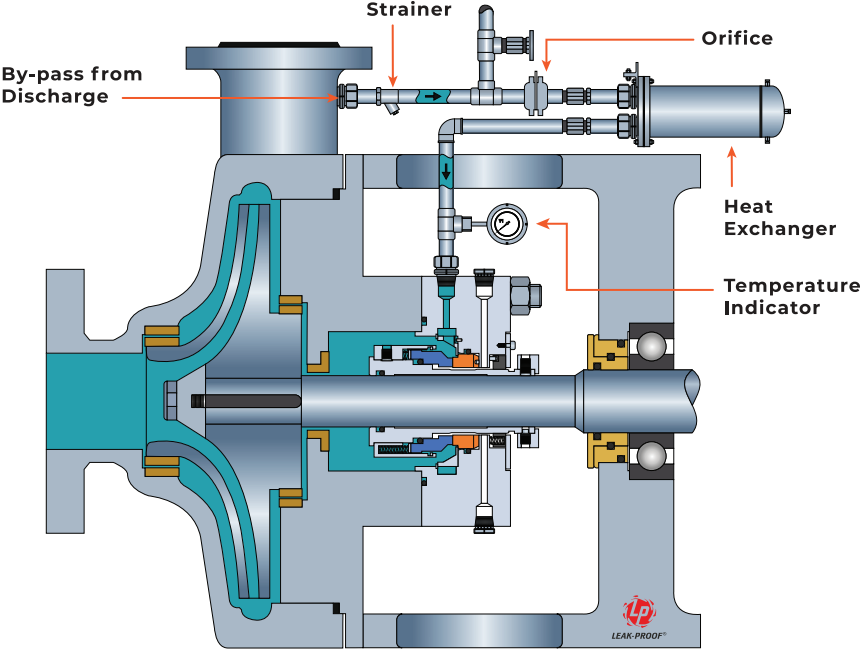

FLUSH PLAN - SINGLE SEALS / DOUBLE SEALS (INBOARD) PLAN 22

Description

Plan 22 is a (Plan 21 + Strainer) flush plan with product circulation from the pump discharge through a strainer, flow control orifice and Heat exchanger to the seal chamber for seal faces cooling and lubrication.

Features

1. In addition to plan 21 features, it can handle dirty products up to certain extent.

Application

1. Application with slightly contaminated (fluids with suspended solids) and non-polymerizing fluids with high temperature.

Precautions

1. Always ensure that the strainer is placed first before orifice in the direction of flow.
2. Not recommended due to strainer unreliability and also not proven to achieve a 3-year operating life.
3. Recommended to use with differential pressure indicator or alarm to know the strainer clogging status and avoid seal failure.

PLAN 23 | Flush Plan – Closed loop circulation through Heat Exchanger

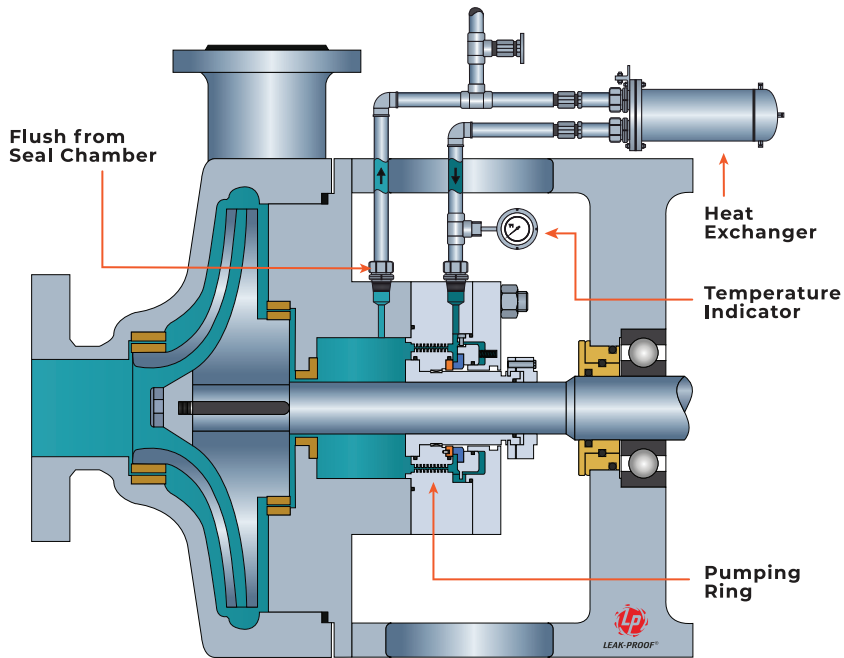

FLUSH PLAN - SINGLE SEALS / DOUBLE SEALS (INBOARD) **PLAN 23**

Description

Plan 23 is a closed-loop system to circulate product from the seal chamber through a heat exchanger and back to the seal chamber using a pumping ring.

Features

1. The hot pumping product is isolated from the seal chamber fluid by the throat bush and the temperature inside the seal chamber stables at a lower temperature than the pumping product temperature.
2. In running condition, circulation is maintained by pumping ring whereas in static condition circulation happens through thermosyphon effect.

Application

1. Applications with high temperature and clean fluid e.g., Boiler feed water, hot hydrocarbon, etc.

Precautions

1. Ensure high point vent valve in piping system and vent the system before start up.
2. Close clearance throat bushing is recommended to isolate hot pumping product with seal chamber circulating fluid.
3. A distributed flush is not recommended with plan 23.

PLAN 31 | Flush Plan – By-pass from Discharge through Abrasive Separator

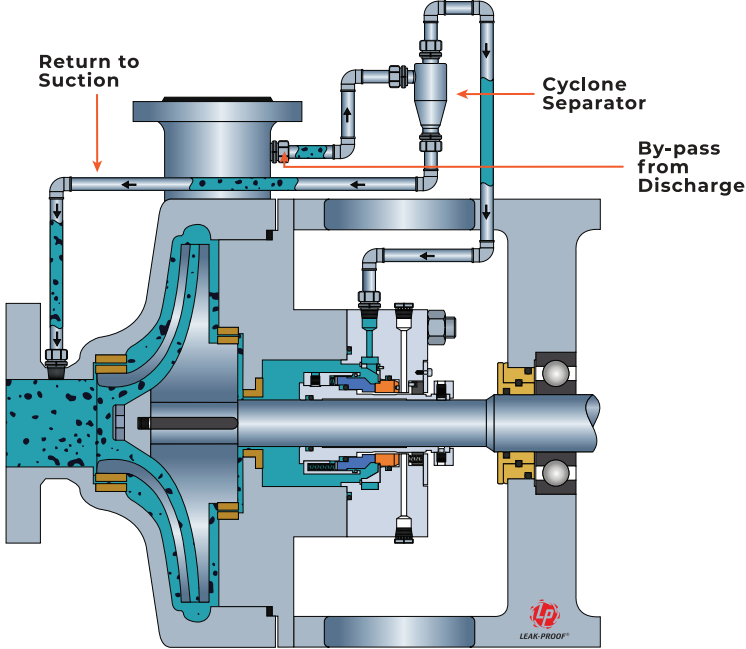

FLUSH PLAN - SINGLE SEALS / DOUBLE SEALS (INBOARD) **PLAN 31**

Description

Plan 31 is a flush plan with product circulation from the pump discharge through an abrasive separator (cyclone separator), which directs product to the seal chamber and forward separated abrasives back to the pump suction.

Features

1. Separates abrasives from process fluid before entering to seal chamber.
2. Separated abrasives are sent back to pump suction.

Application

1. Applications with heavy suspended abrasives or solids.

Precautions

1. Ensure the specific gravity of the abrasive solids is at least twice of the pumping fluid.
2. Close clearance throat bushing must be ensured.
3. Due to abrasive wear inside the cyclone separator this plan has not proven to achieve a 3-year operating life.
4. Wear in cyclone separator must be inspected timely in routine.

PLAN 32 | Flush Plan – Flush from External Source

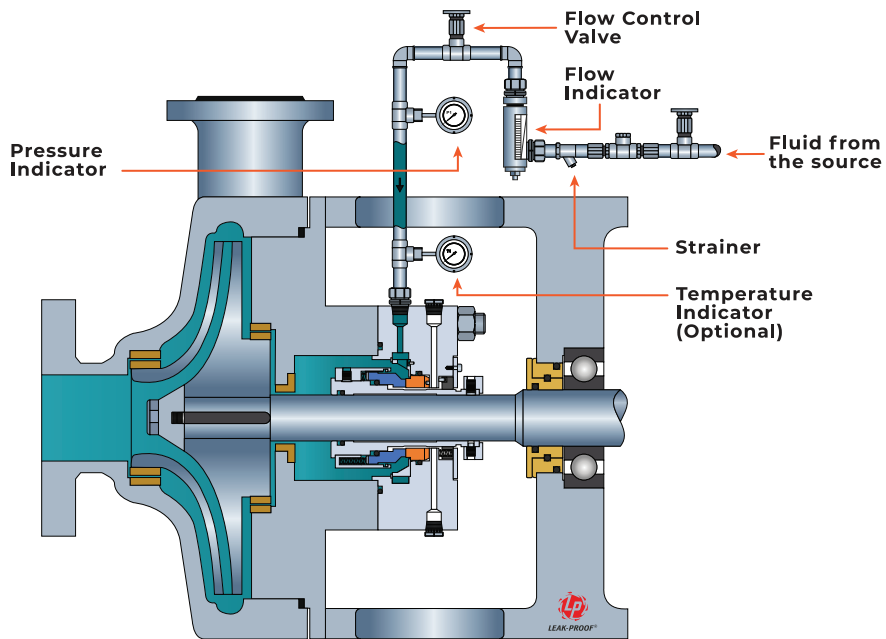

FLUSH PLAN - SINGLE SEALS / DOUBLE SEALS (INBOARD) PLAN 32

Description

Plan 32 is a flush plan with clean fluid injection from the external source into the seal chamber.

Features

1. Vapor pressure margin is maintained and the chances of flashing or air intrusion around seal faces is reduced due to positive seal flush.
2. Considered a best plan to provide among all plans, provided external flush fluid dilution in product is acceptable.

Application

1. Applications with slurry, solids and contaminants where product dilution is acceptable.
2. Can be used for products with poor lubricity.
3. Can be used in horizontal and vertical pumps.

Precautions

1. Shutdown or failure in external fluid supply in use could result in seal failure.
2. The external flush fluid must be compatible with pumping product.
3. Pumping product dilutes due to injection of flush fluid from outside.
4. Close clearance throat bushing must be provided to create pressure difference and control the dilution (flow) in to the product.
5. Consider the external flush fluid expenses as it might be expensive depending on situation.

PLAN 41 | Flush Plan – By-pass from Discharge through Abrasive Separator & Heat Exchanger

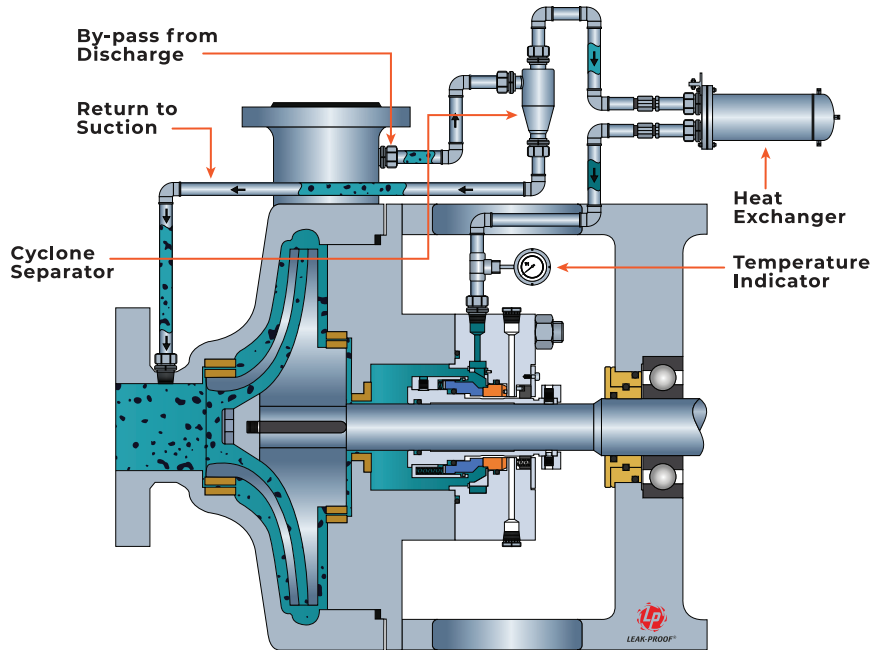

FLUSH PLAN - SINGLE SEALS / DOUBLE SEALS (INBOARD) PLAN 41

Description

Plan 41 is a (Plan 21 + Plan 31) flush plan with product circulation from the pump discharge through an abrasive separator (cyclone separator) and heat exchanger to the seal chamber and forward separated abrasives back to the pump suction.

Features

1. This plan possesses the combined feature of both Plan 21 and Plan 31 together in a single plan.
2. Reduces product solids and temperature to enhance seal environment.

Application

1. Applications with heavy suspended abrasives or solids at high temperature.

Precautions

1. All the points of precautions as mentioned in parent plans, Plan 21 and Plan 31 must be considered.
2. Failure in cyclone separator could choke the Heat exchanger and stop the flush supply and fail the seal.
3. Does not provide continuous reliable operation as frequent maintenance is required due to cyclone separator body wear and abrasion.

PLAN 52 | Buffer Plan – Unpressurised Liquid from Accumulator

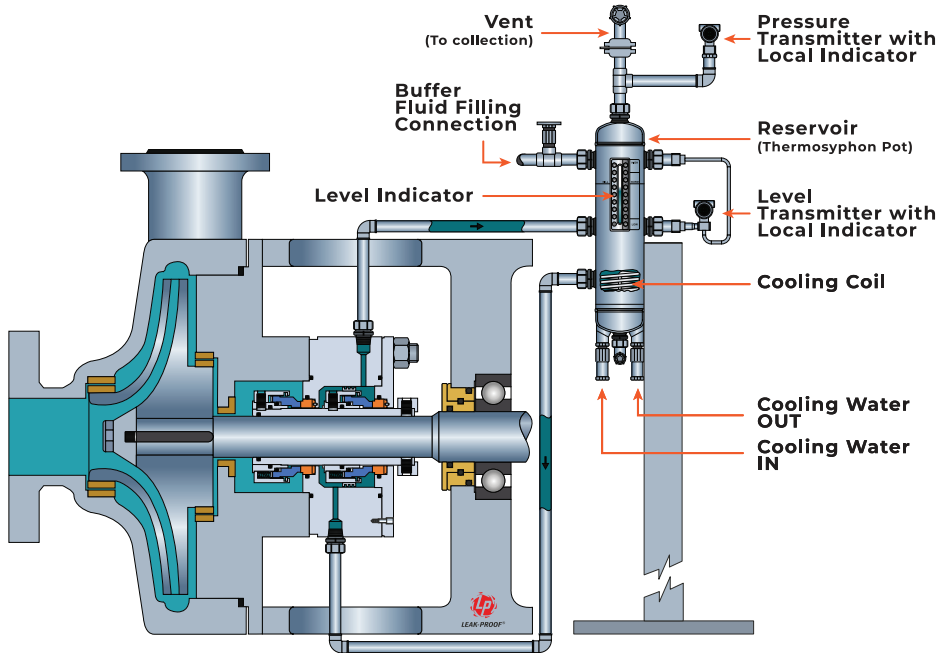

LIQUID BARRIER / BUFFER PLAN - DOUBLE SEALS PLAN 52

Description

Plan 52 is an unpressurized buffer plan uses an external reservoir to provide buffer fluid between the seals of an unpressurized double seal (Arrangement 2). The buffer fluid pressure is maintained in the piping system through the reservoir at a pressure less than the seal chamber pressure. Flow is induced by a pumping ring.

Features

1. The leakage from the seal is not exposed to the atmosphere directly.
2. Seal leaks from the high-pressure seal chamber to the low-pressure buffer fluid hence no product contamination is happening.
3. This plan is operated without pressure supply i.e., at atmospheric pressure.
4. The cooling coil inside the reservoir or an external water or air cooler removes heat from the buffer fluid.

Application

1. Used for flashing (light hydrocarbon) and non-flashing services.
2. Used where product dilution is not acceptable but product exposure to the atmosphere in diluted form is acceptable.

Precautions

1. Buffer fluid pressure must be less than the seal chamber pressure and below 2.8 bar.
2. Should not be used for contaminated and polymerizing process fluid.
3. Vent system properly before start up.
4. Rise in either reservoir pressure or reservoir buffer fluid level is an indication of inboard seal leakage.
5. Fall in reservoir buffer fluid level is an indication of outboard seal leakage.

PLAN 53A | Barrier Plan – Pressurised Liquid from Accumulator

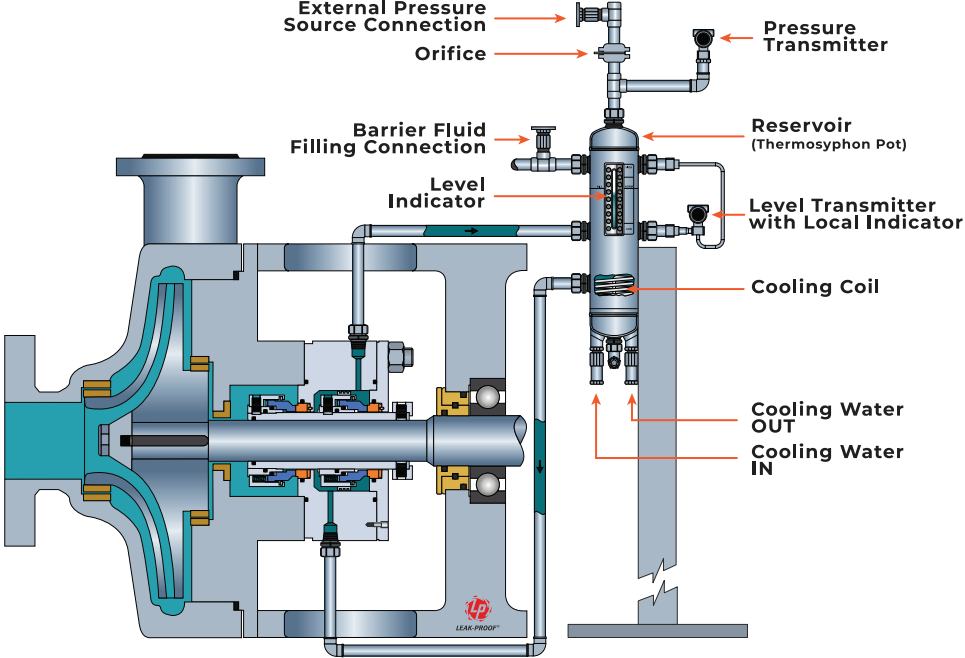

Description

Plan 53A is a pressurized barrier plan uses an external reservoir to provide barrier fluid between the seals of a pressurized double seal (Arrangement 3). The barrier fluid pressure is maintained in the piping system through the reservoir by gas (nitrogen) at a pressure greater than the seal chamber pressure. Flow is induced by a pumping ring.

Features

1. The leakage from the seal is not exposed to the atmosphere (Unless there is no pressure loss in the support system).
2. Undesired process fluid film formation between the faces is overcome by using high pressure clean barrier fluid.
3. Works as Plan 52 in case of barrier pressure loss.
4. The cooling coil inside the reservoir or an external water or air cooler removes heat from the buffer fluid.

Application

1. Applications e.g., hazardous, toxic, inflammable process fluid where leakage to atmosphere is intolerable.
2. Used where product dilution is acceptable or product fluid is unsuitable for lubricating the inner seal (e.g., abrasive, contaminated and polymerizing process fluid)

Precautions

1. Ensure that the barrier pressure is always higher than the seal chamber pressure (At least 1.4 bar).
2. Barrier fluid leakage adds in the product fluid. Hence check the barrier fluid compatibility with product fluid.
3. Inert gas (nitrogen) used to apply pressure can dissolve in barrier fluid in some cases.
4. Fall in reservoir barrier fluid pressure and level is an indication of inboard or/and outboard seal leakage.
5. Vent system properly before start up.

PLAN 53B | Barrier Plan – Pressurised Liquid from Accumulator through Heat Exchanger

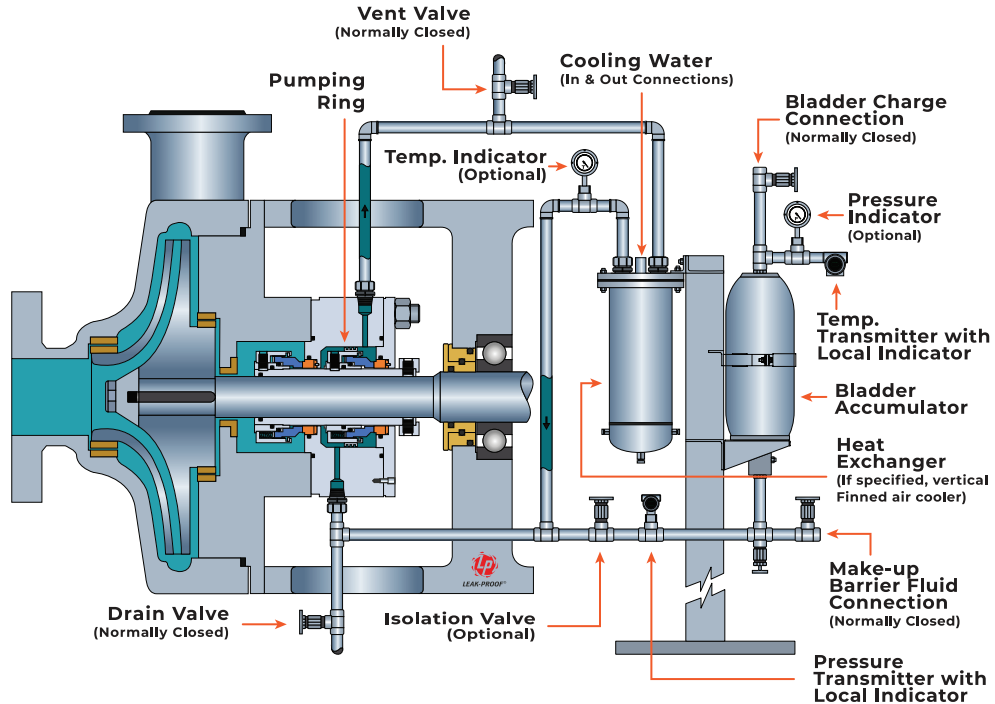

Description

Plan 53B is a pressurized barrier plan uses a bladder accumulator to pressurize the barrier fluid between the seals of a pressurized double seal (Arrangement 3). The pressurized barrier fluid is isolated by gas (nitrogen) through bladder. A water or air-cooled heat exchanger provides for barrier fluid cooling. Flow is induced by a pumping ring.

Features

1. Inert gas dissolve issue is eliminated as fluid is separated using bladder.
2. The leakage from the seal is not exposed to the atmosphere (Unless bladder pressure is lost).
3. Undesired process fluid film formation between the faces is overcome by using high pressure clean barrier fluid.
4. Use of cooler right after seal outlet helps to bring the barrier fluid temperature down under bladder temperature limit.

Application

1. Applications e.g., hazardous, toxic, inflammable process fluid where leakage to atmosphere is intolerable.
2. Used where product dilution is acceptable or product fluid is unsuitable for lubricating the inner seal (e.g., abrasive, contaminated and polymerizing process fluid).

Precautions

1. Ensure that the barrier pressure is always higher than the seal chamber pressure (At least 1.4 bar).
2. The barrier fluid selected should be chemically compatible with process fluid and bladder material.
3. Precharge accumulator at correct pressure with respect to ambient temperature.
4. Fall in barrier fluid pressure is an indication of inboard or/and outboard seal leakage.
5. Vent system properly before start up.

PLAN 53C | Barrier Plan – Pressurised Liquid from Piston Accumulator through Heat Exchanger

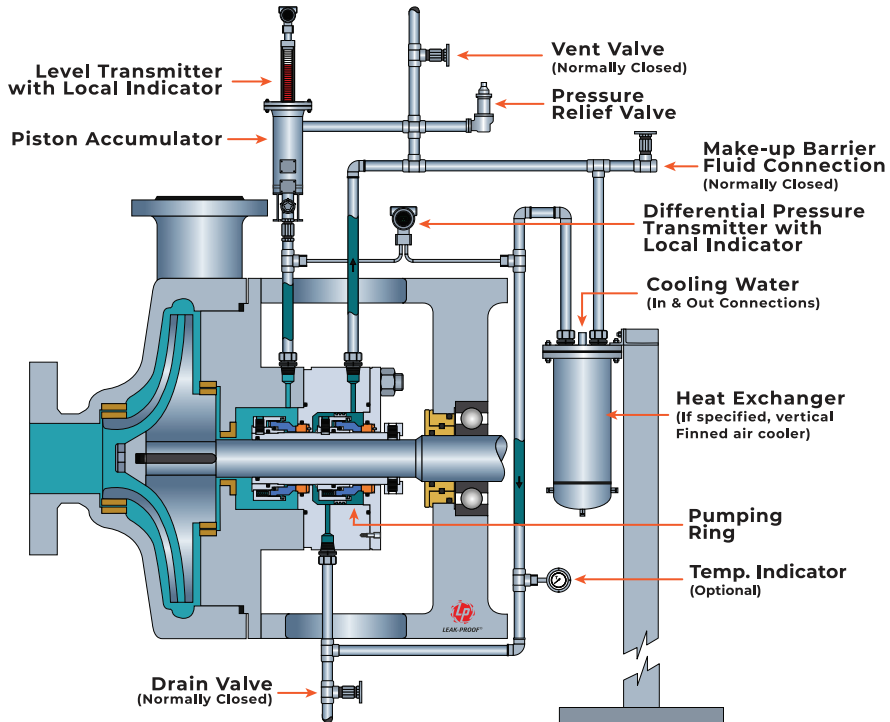

Description

Plan 53C is a pressurized barrier plan that uses a piston accumulator to pressurize the barrier fluid between the seals of a pressurized double seal (Arrangement 3). It uses a reference line from the seal chamber to compensate for the fluctuation in barrier pressure using a piston accumulator. A water or air-cooled heat exchanger provides for barrier fluid cooling. Flow is induced by a pumping ring.

Features

1. Use the seal chamber pressure as a reference and magnify the barrier pressure by a predefined ratio.
2. Undesired process fluid film formation between the faces is overcome by using high-pressure clean barrier fluid.
3. No need for an external pressure source

Application

1. Applications e.g., hazardous, toxic, inflammable process fluid where leakage to the atmosphere is intolerable.
2. Used where product dilution is acceptable or product fluid is unsuitable for lubricating the inner seal (e.g., abrasive, contaminated and polymerizing process fluid).
3. For services where 53A and 53B can not be used due to nitrogen unavailability.

Precautions

1. Ensure that the barrier pressure is always higher than the seal chamber pressure (At least 1.4 bar).
2. The barrier fluid selected should be chemically compatible with process fluid.
3. The reference line to the accumulator must be tolerant of process contamination without plugging.
4. Vent system properly before start up.

PLAN 54 | Barrier Plan – Pressurised Liquid from External Source

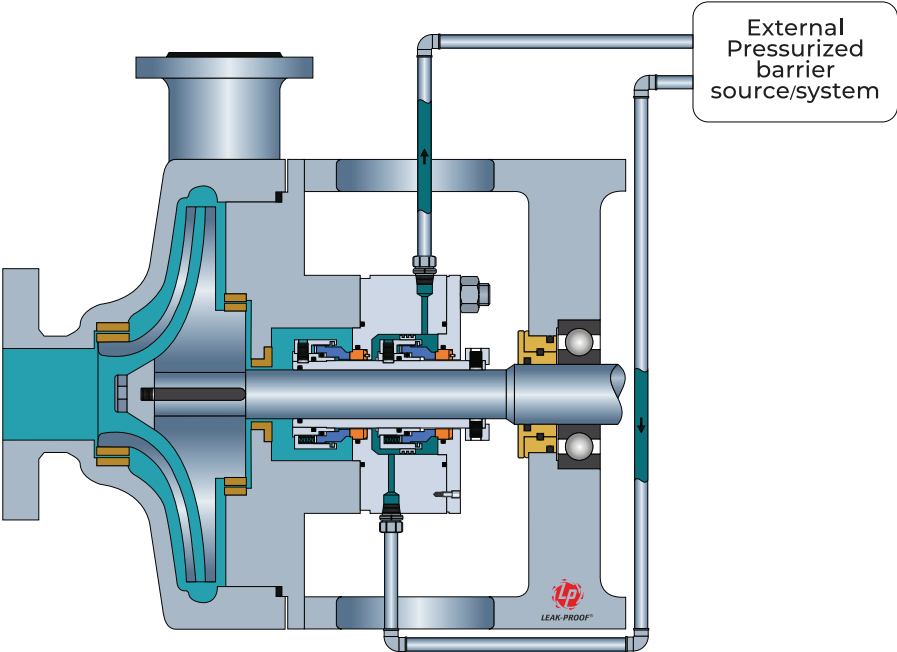

LIQUID BARRIER / BUFFER PLAN - DOUBLE SEALS **PLAN 54**

Description

Plan 54 is a pressurized external barrier fluid supply system that supplies clean barrier fluid between the seals of a pressurized double mechanical seal (Arrangement 3) at a pressure higher than the seal chamber pressure. An external pump or pressure system circulates the barrier fluid through a water or air cooler in the system.

Features

1. It is more reliable than Plan 53A/B/C as it provides a higher flow rate with better heat dissipation and continuous positive circulation of barrier fluid in running as well as standby conditions.
2. An external pump is used to create flow.
3. It can be custom-engineered to suit application requirements.
4. It can provide pressurized flow to multiple seal installations to reduce costs.

Application

1. Applications like hazardous, toxic, inflammable and abrasive or polymerizing product fluids.
2. Applications with high pressure and/or high temperature and/or high face heat generation.
3. Wherever circulation provided in Plan 53A/B/C is insufficient to dissipate heat.

Precautions

1. Ensure that the barrier pressure is always higher than the seal chamber pressure (At least 1.4 bar).
2. Barrier fluid selected should be compatible with the process fluid.
3. Loss of pressure in the system can lead to entire barrier fluid contamination.

LIQUID BARRIER / BUFFER PLAN - DOUBLE SEALS **PLAN 55**

Description

Plan 55 is an unpressurized external buffer fluid supply system that supplies clean buffer fluid between the seals of an unpressurized double mechanical seal (Arrangement 2) at a pressure lower than the seal chamber pressure. An external pump or pressure system circulates the buffer fluid through a water or air cooler in the system.

Features

1. It is more reliable than Plan 52 as it provides a higher flow rate with better heat dissipation and continuous positive circulation of buffer fluid in running as well as standby conditions.
2. An external pump is used to create flow.
3. No product contamination and direct leakage to atmosphere.
4. It can be custom-engineered to suit application requirements.
5. It can provide pressurized flow to multiple seal installations to reduce costs.

Application

1. Used for flashing (light hydrocarbon) and non-flashing services.
2. Used where product dilution is not acceptable but product exposure to the atmosphere in diluted form is acceptable.
3. Wherever circulation provided in Plan 52 is insufficient to dissipate heat.

Precautions

1. Buffer fluid pressure must be less than the seal chamber pressure and below 2.8bar.
2. Should not be used for contaminated and polymerizing process fluid.
3. Ensure the compatibility of buffer fluid with product fluid.

PLAN 71 | Buffer Plan – Tapped Connection for Purchaser's Use

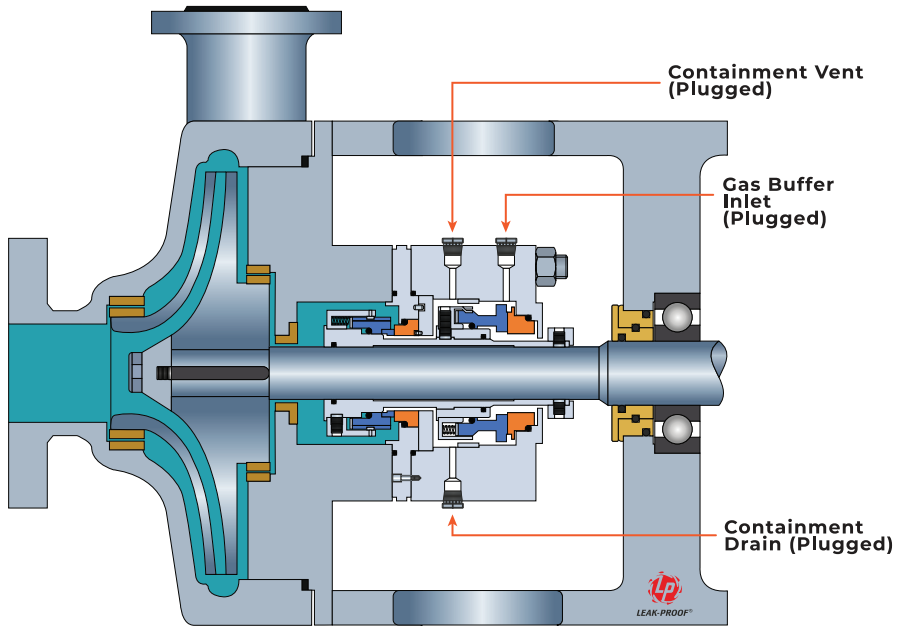

Description

Plan 71 is plugged connection for possible use of buffer gas in future by the user.

Features

1. Allows user to add a buffer gas (Plan 72) in future with Plan 76 and Plan 75.

Application

1. Used for flashing (light hydrocarbon) and non-flashing services.
2. Used for contacting as well as non-contacting seals with provision for future use of Plans 72, 75 or/and 76 is desired.

Precautions

1. Ensure that the metallic plugs are used.
2. Ensure that the vent port is on top and drain port is on bottom position.

PLAN 72 | Buffer Plan – Low pressure gas injection to Outboard Seal cavity

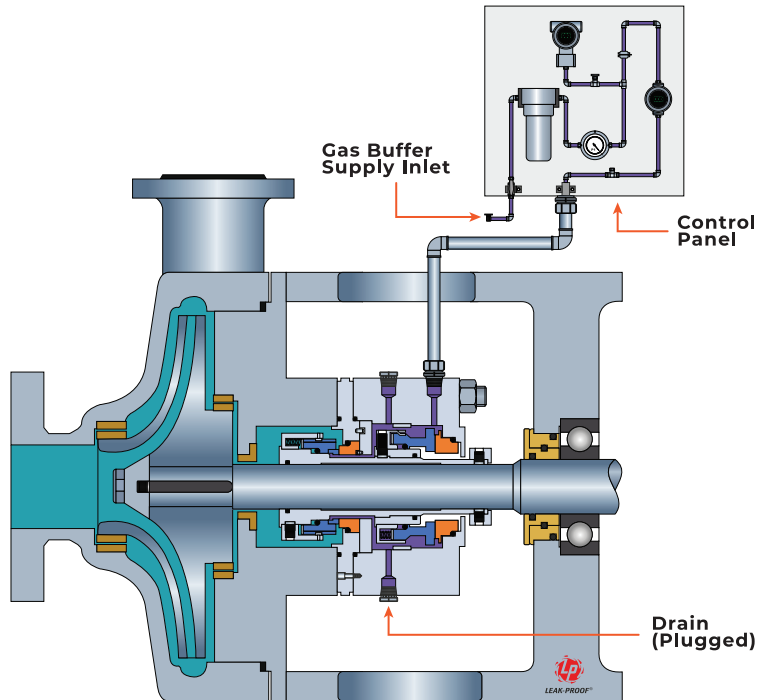

Description

Plan 72 is an unpressurized external buffer gas supply system that supplies clean buffer gas (nitrogen) between the seals of an unpressurized double mechanical seal (Arrangement 2) with a dry running containment seal at a pressure lower than the seal chamber pressure.

Features

1. Helps to collect primary seal leakage either in condensing or non-condensing form without exposure to the atmosphere.
2. The rise in explosion hazard due to leakage from the inboard seal is reduced.
3. Prevents icing in cryogenic applications.

Application

1. May be used for flashing (light hydrocarbon) and non-flashing services.
2. Used together with Plan 75 (for condensing leakage) or/and Plan 76 (for vaporizing leakage).

Precautions

1. Buffer gas pressure must be less than the seal chamber pressure and should not exceed 0.7bar.
2. Set the forward pressure control valve at minimum 0.4 bar above flare back pressure.
3. Ensure that the vent port is on top and drain port is on bottom position.

PLAN 74 | Barrier Plan – Pressurised gas injection for Dual Gas Seal

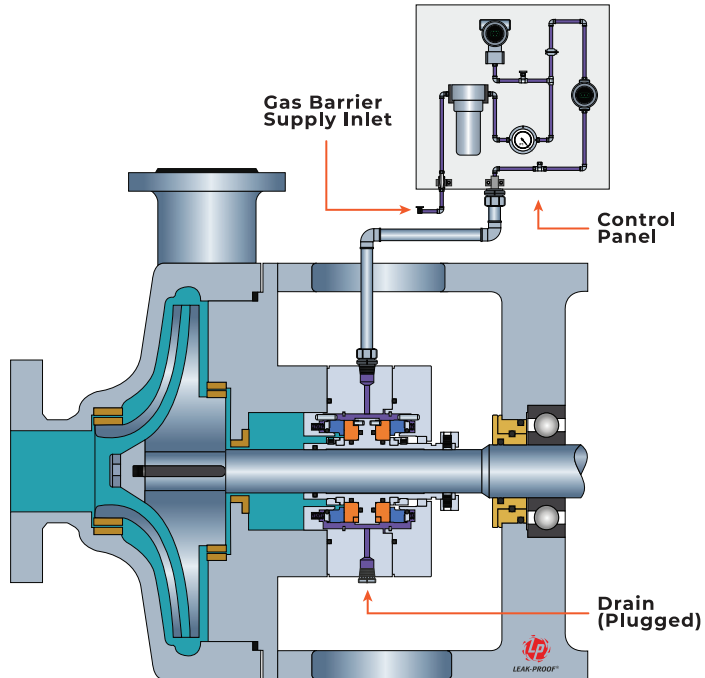

Description

Plan 74 is a pressurized external barrier gas supply system that supplies clean barrier gas (nitrogen) between the seals of a non-contacting pressurized double mechanical seal (Arrangement 3) at a pressure higher than the seal chamber pressure.

Features

1. The leakage from the seal is not exposed to the atmosphere.
2. A cleaned nitrogen barrier gas supply makes it highly reliable.

Application

1. For double pressurized non-contacting seals.
2. Flashing light hydrocarbons.
3. Applications e.g., hazardous, toxic, inflammable process fluid where leakage to the atmosphere is intolerable.
4. Used where product dilution is acceptable or product fluid is unsuitable for lubricating the inner seal (e.g., abrasive, contaminated and polymerizing process fluid).

Precautions

1. Ensure that the barrier gas pressure is always higher than the seal chamber pressure (At least 1.7 bar).
2. Set the pressure control valve at least 1.7 bar above the seal chamber pressure.
3. Use individual gas panel per seal assembly in between bearing pump.

PLAN 51 | Quench Plan – Quench Blanket

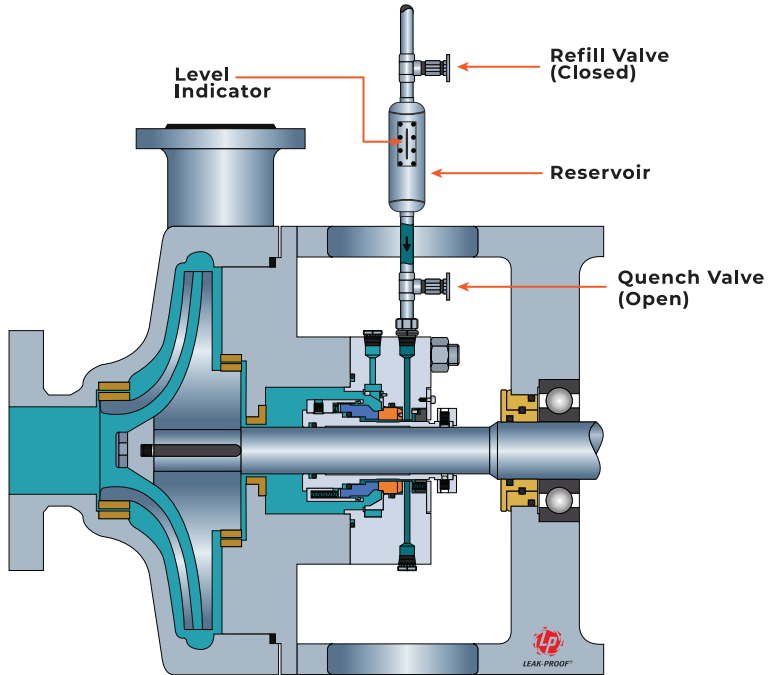

Description

Plan 51 is an external reservoir providing a dead-ended blanket of fluid to the quench connection of the gland. Typically used with an auxiliary sealing device.

Features

1. Helps to prevent icing on the atmospheric side of the seal.
2. No need to maintain pressure in the system.

Application

1. For product fluid that undergoes crystallization or ice formation on the atmospheric side of the seal.
2. Vertical pumps with dead-ended atmospheric quench.

Precautions

1. Recommended to use in vertical pumps only.
2. Escape of blanket fluid from the reservoir depends on the type of auxiliary sealing device used. Hence not possible to achieve a 3-year operating life.

PLAN 61 | Quench Plan – Quench Connection for Purchaser's Use

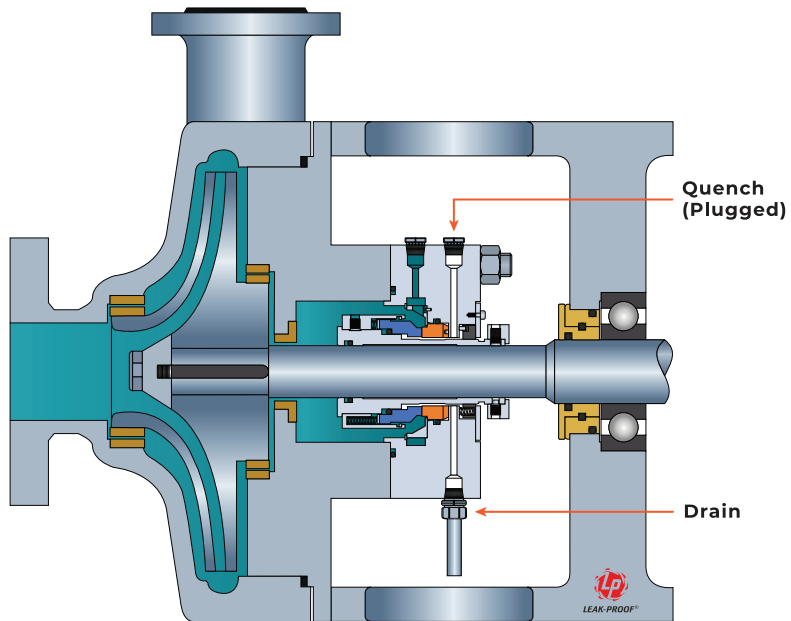

Description

Plan 61 is plugged connection for possible use of quench Plan 62 or Plan 65 in future by the user.

Features

1. The quench and drain connection when piped is converted to Plan 62.
2. The drain connection can be piped to connect to drain collection system (Plan 65).

Application

1. Used in single seals (can be used in double seals also).
2. On horizontal or vertical pumps having possible future use for Plan 62 or Plan 65.

Precautions

1. Ensure that the metallic plugs are used.
2. Always keep the ports plugged.

PLAN 62 | Quench Plan – Quench on Atmospheric Side

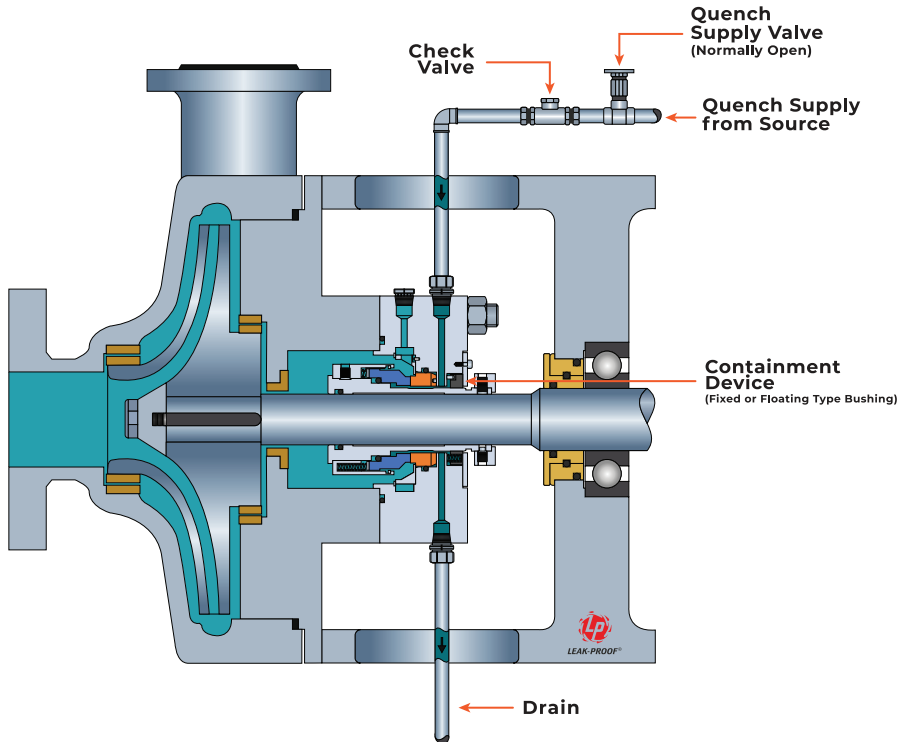

Description

Plan 62 is an external common quench plan to improve the environment on the atmospheric side of the seal faces by quenching with low pressure steam, nitrogen or water.

Features

1. The quench prevents or retards product crystallization, coking and also provide cooling to seal faces.
2. Flushes away undesirable material build up under seal faces.
3. Can be used with steam, nitrogen or water.

Application

1. Steam quench to reduce coking in hot services.
2. Nitrogen quench to prevent icing.
3. Water quench to prevent crystallization or accumulation of undesirable material build up under seal faces.
4. Applied to horizontal as well as vertical pumps.

Precautions

1. For steam quench a steam trap is recommended.
2. Ensure that a close clearance throttle bush is fitted on the atmospheric side of the seal.
3. Ensure quench pressure between 0.2 to 0.3 barg.

PLAN 65A | Collection Plan – Leakage collection/detection by excess flow into system

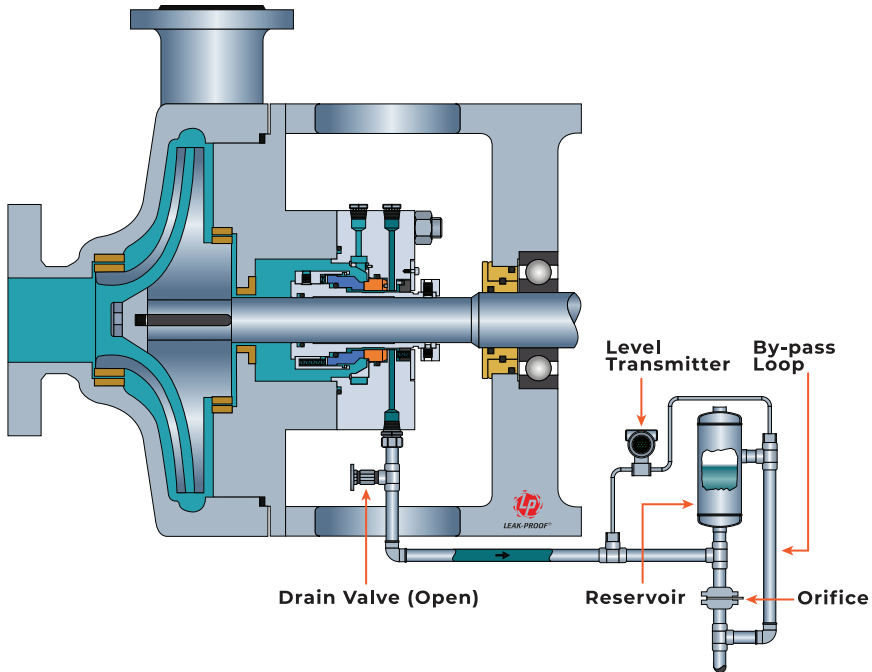

Description

Plan 65A is a seal face leakage collection and detection system in which leakage is directed through a vessel and orifice to the liquid collection system. The vessel is provided with a high-level alarm for detecting excess leakage.

Features

1. Used where the leakage is expected to be in liquid (condensing leakage).
2. Provides an alarmed indication of excessive seal leakage that can shut down equipment if necessary.
3. The loop to bypass the orifice prevents high pressure built up on the atmospheric side of the seal.

Application

1. For single seals with condensing leakage.

Precautions

1. The vent connection should always be plugged.
2. The drain should be located at the bottom-most position and the valve below the gland should always kept open during pump operation.
3. An orifice should be installed in the vertical piping leg to avoid the accumulation of leaks in the drain piping.
4. Reservoir must be located below the seal gland.

PLAN 65B | Collection Plan – Leakage collection/detection by cumulative leakage into system

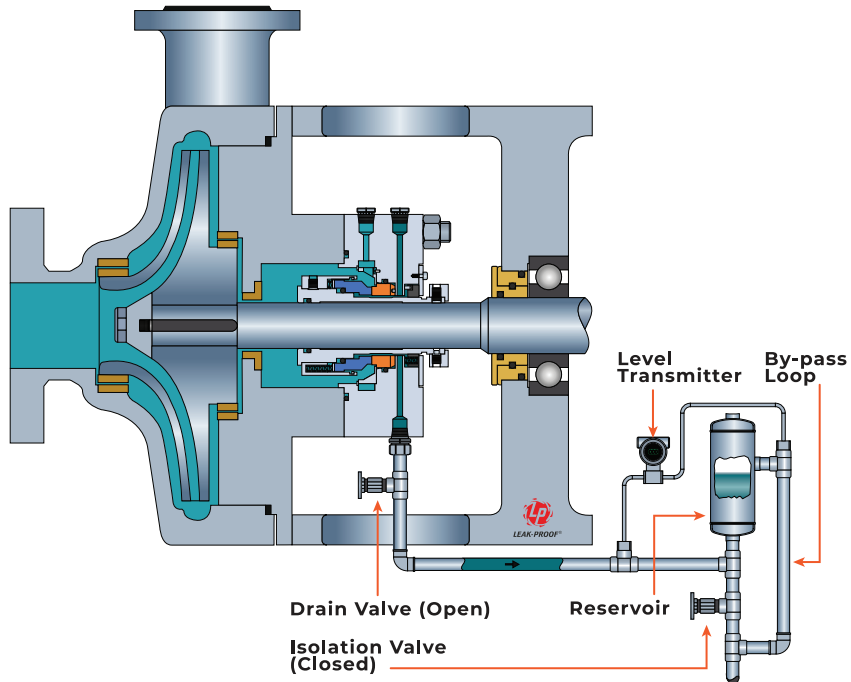

Description

Plan 65B is a seal face leakage collection and detection system in which leakage is directed through a vessel to the liquid collection system. The vessel is provided with a high-level alarm for detecting cumulative leakage.

Features

1. Used where the leakage is expected to be in liquid (condensing leakage).
2. Provides an alarmed indication of seal leakage that can shut down equipment if necessary.
3. Identical to Plan 65A except it uses a normally closed valve in place of orifice of plan 65A.
4. The loop to bypass the normally closed valve prevents high pressure built up on the atmospheric side of the seal.

Application

1. For single seals with condensing leakage.

Precautions

1. The vent connection should always be plugged.
2. The drain should be located at the bottom-most position and the valve below the gland should always kept open during pump operation.
3. Reservoir must be located below the seal gland.

PLAN 66A | Collection Plan - Leakage detection arrangement with Throttle Bushing

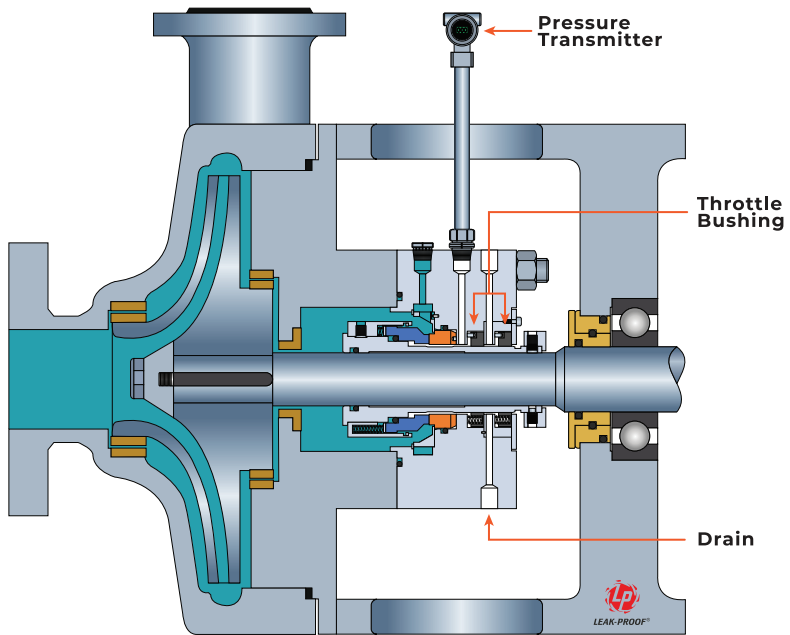

Description

Plan 66A is a leakage detection plan. Throttle bushings in the seal gland restrict the seal leakage and a pressure transmitter is used to monitor seal leakage and set off an alarm when leakage becomes excessive or in the case of seal failure.

Features

1. Normal leakage continues to flow freely to the drain port.
2. Excess leakage is restricted by throttle bushing and built pressure to trigger an alarm on seal failure.

Application

1. For single seals with a requirement of limiting leakage in case of seal failure.

Precautions

1. Ensure that the leakage from the drain port is collected and piped to a liquid recovery system or sump.
2. The drain should be located at the bottom-most position.

PLAN 66B | Collection Plan - Leakage detection arrangement with Orifice Plug

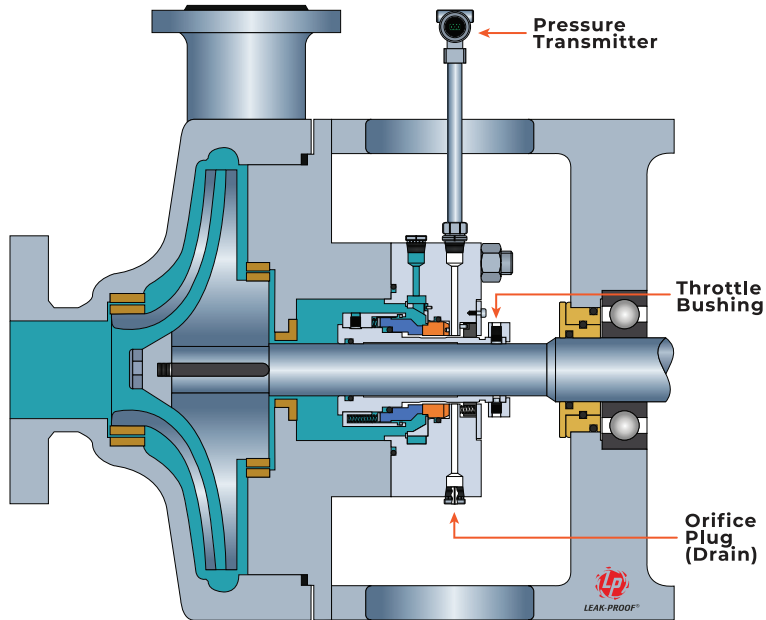

Description

Plan 66B is a leakage detection plan. An orifice plug in the drain port of the seal gland restricts the seal leakage and a pressure transmitter is used to monitor seal leakage and set off an alarm when leakage becomes excessive or in the case of seal failure.

Features

1. Normal leakage passes through orifice plug to the drain.
2. Excess leakage is restricted by an orifice plug and built pressure to trigger an alarm on seal failure.

Application

1. For single seals with a requirement of limiting leakage in case of seal failure.

Precautions

1. Ensure that the leakage from the drain port is collected and piped to a liquid recovery system or sump.
2. The drain should be located at the bottom-most position.

PLAN 75 | Collection Plan – Leakage collection for condensing fluid

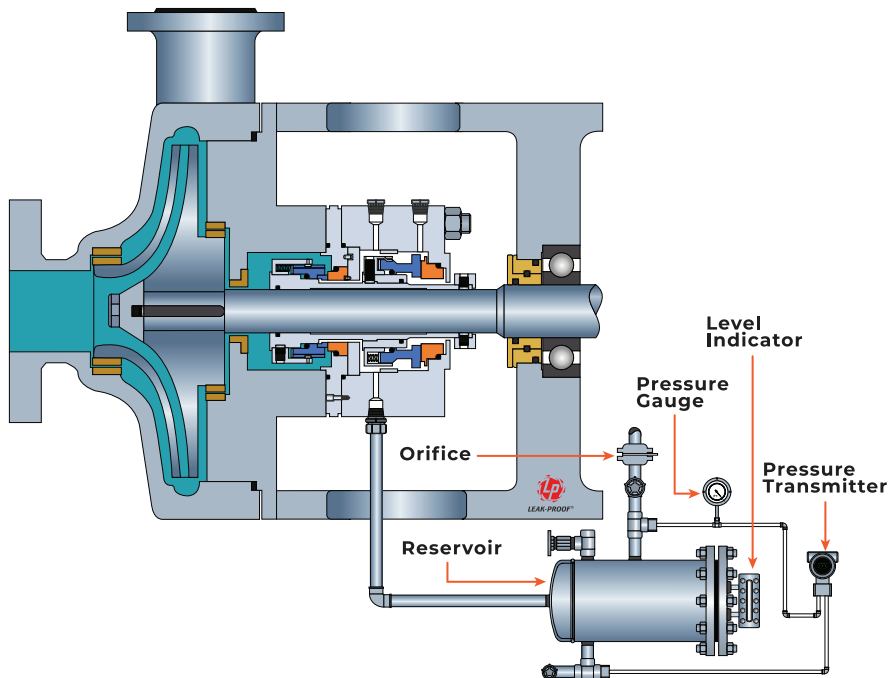

Description

Plan 75 is a leakage collection system used to collect the leakage condensate from the inboard seal of the double unpressurized seal with a containment seal (Arrangement 2) and direct it to a liquid collector.

Features

1. This plan can be used with Plan 72 with buffer gas or with Plan 71 without buffer gas.
2. Avoid direct leakage of product fluid to the atmosphere.
3. Leakage collected can be sent back to process fluid.

Application

1. Services with condensing leakage.
2. Hazardous, toxic & inflammable fluid.

Precautions

1. Ensure that the collection system is located below the seal drain.
2. The drain should be located at the bottom-most position.
3. The pressure transmitter in the leakage collector should be set to alarm at a gauge pressure of 0.7 bar.
4. Ensure that the vent line is open and an orifice is present to generate back pressure.

PLAN 76 | Collection Plan – Venting for non-condensing fluid

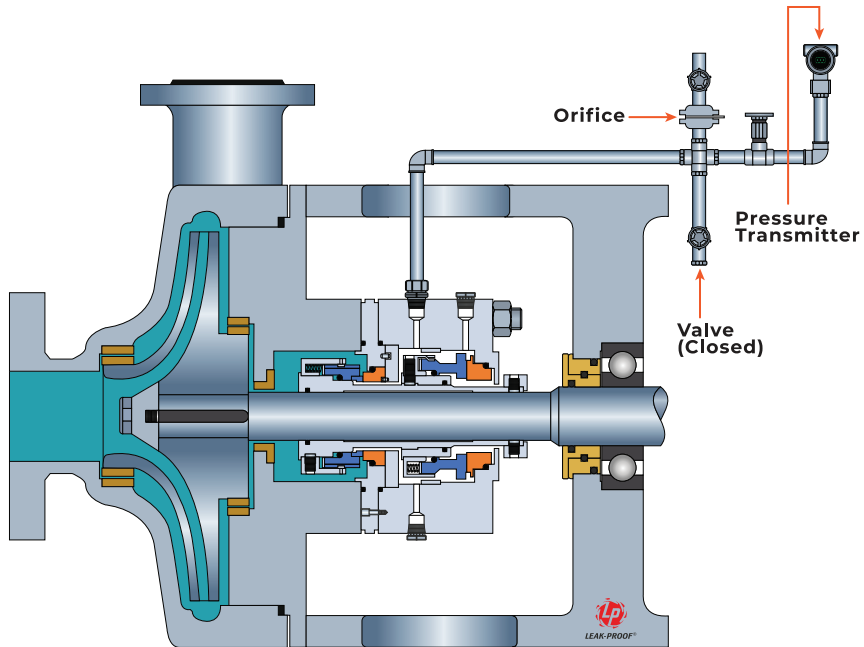

Description

Plan 75 is a leakage collection system used to collect the vapour leakage from the inboard seal of the double unpressurized seal with a containment seal (Arrangement 2) and direct it through vent to a vapour recovery system.

Features

1. This plan can be used with Plan 72 with buffer gas or with Plan 71 without buffer gas.
2. Ensures almost no product emissions from outboard containment seal to the atmosphere.

Application

1. For non-condensing fluid - typically high vapour pressure fluids and light hydrocarbons.
2. Hazardous, toxic & inflammable fluid.

Precautions

1. Do not use for condensing product fluid.
2. Ensure low point condensate drain.
3. The drain should be located at the bottom-most position.
4. The pressure transmitter in the vapour collector should be set to alarm at a gauge pressure of 0.7 bar.
5. Ensure that the vent line is open and an orifice is present to generate back pressure.

PLAN 99 | Special Plan – Engineered Piping Plan not defined in any other Piping Plan

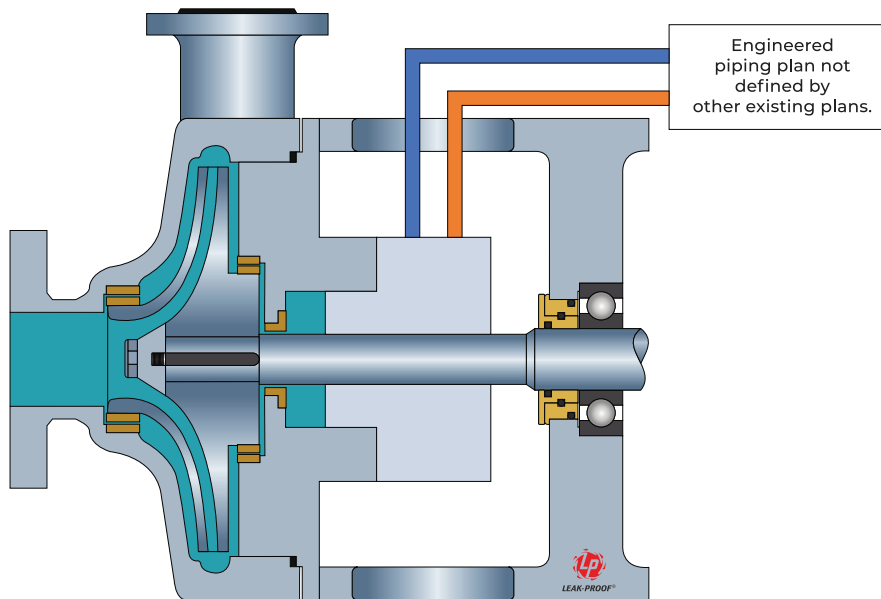

Description

Plan 99 defines an engineered piping plan not defined by any existing plans.

Features

1. This is an engineered system to suit the specific requirements of the customer.

Application

1. Can be applicable to any seal arrangement.

Precautions

1. Detailed engineering and detailed discussion between the seal manufacturer and client is required for effective solution.

USEFUL INFORMATION

Applications & Temperature Limits for Barrier / Buffer Fluids				
FLUID FAMILY	FLUID / SOLUTION GRADE	APPLICATION	TEMPERATURE LIMIT	
			°C	°F
Water	—	Low Duty, Water Food Processing, Pharma	5 to 70	40 to 160
Alcohols	Methanol, Propanol	Cryogenics	-110 to 20	-165 to 65
Glycol Solutions	50% Ethylene Glycol + 50% Water	Light Hydrocarbons	-35 to 100	-30 to 210
Hydrocarbons	Kerosene or Diesel	Light Hydrocarbons & Medium Duty	-10 to 80	15 to 175
Lubricating Oils	Below ISO Grade 32	General Purpose & Heavy Duty	-20 to 150	-5 to 300
Synthetic Oils	ISO Grade 5 to Grade 20	General Purpose & Heavy Duty with High Temperature	-30 to 250	-20 to 480
Heat Transfer Fluids	Therminol VP-1, Dowtherm A or Equivalent	Very High Temperature	-30 to 400	-20 to 750

USEFUL INFORMATION

Temperature Range & Limitations for elastomers used in Mechanical Seals

MATERIAL	TEMPERATURE LIMIT		LIMITATIONS
	°C	°F	
Nitrile	-40 to +120	-40 to +250	Maximum limit in water duties is 100°C (212°F)
Neoprene	-30 to +100	-22 to +210	
Fluoroelastomer (FKM)	-20 to +200	-4 to +400	Maximum limit in water duties is 120°C (248°F)
Perfluoroelastomer (FFKM)	-20 to +270	-4 to +520	
EPDM	-40 to +150	-40 to +300	
Fluorosilicone	-60 to +175	-75 to +350	
Silicone	-55 to +200	-65 to +390	
TFE-P	0 to +250	+32 to +400	
PTFE	-75 to +230	-100 to +440	
GFT (Glass-filled PTFE)	-212 to +250	-345 to +480	
Grafoil®	-270 to +480	-345 to +480	

USEFUL CONVERSIONS

TO CONVERT FROM

TO CONVERT TO

LENGTH	μm	mm	cm	m	μin	In	Feet	Yard
MULTIPLY BY								
μm	1	0.001	0.0001	0.000001	39.37	3.94E-05	3.28E-06	1.09E-06
mm	1000	1	0.1	0.001	39370	0.03937	0.003281	0.001094
cm	10000	10	1	0.01	393701	0.3937	0.03281	0.01094
m	100000	1000	100	1	39370080	39.37	3.281	1.094
μin	25.4	0.0254	0.00254	2.54E-05	1	8.33E-05	6.94E-06	2.32E-06
In	25400	25.4	2.54	0.0254	64516	1	0.08333	0.02778
Feet	304800	304.8	30.48	0.3048	1200000	12	1	0.3333
Yard	914400	914.4	91.44	0.9144	3600000	36	3	1

USEFUL CONVERSIONS

TO CONVERT FROM

TO CONVERT TO

AREA	mm ²	cm ²	m ²	km ²	Inches ²	Feet ²	Yards ²
MULTIPLY BY							
mm ²	1	100	1.00E+06	1E+12	645.1546	9.29E+04	8.36E+05
cm ²	1.00E-02	1	1.00E+04	1.00E+10	6.45E+00	9.29E+02	8.36E+03
m ²	1.00E-06	1.00E-04	1	1.00E+06	6.45E-04	9.29E-02	8.36E-01
km ²	1.00E-12	1.00E-10	1.00E-06	1	6.45E-10	9.29E-08	8.36E-07
Inches ²	1.55E-03	0.155	1550	1.55E+09	1	1.44E+02	1.30E+03
Feet ²	1.08E-05	1.08E-03	1.08E+01	1.08E+07	6.94E-03	1	9.00E+00
Yards ²	1.20E-06	1.20E-04	1.20E+00	1.20E+06	7.72E-04	1.11E-01	1

USEFUL CONVERSIONS

TO CONVERT FROM

PRESSURE	tm	Pa (N/m ²)	kPa	MPa (N/mm ²)	kg/cm ²	bar	psi	Torr (mm Hg)
MULTIPLY BY								
tm	1	101325	101.325	0.101325	1.03323	1.01325	14.696	760
Pa (N/m ²)	0.00000987	1	0.001	0.000001	1.02E-05	0.00001	0.000145	0.0075
kPa	0.0000987	1000	1	0.001	0.0102	0.01	0.145	7.5
MPa (N/mm ²)	0.00987	1000000	1000	1	10.2	10	1450	7500
kg/cm ²	0.967841	98066.5	98.0665	0.098067	1	0.967841	14.223	735.59
bar	0.986923	100000	100	0.1	1.03323	1	14.5038	750.06
psi	0.00689	6894.76	6.89476	0.006895	0.070307	0.068948	1	51.715
Torr (mm Hg)	0.00132	133.322	0.133322	0.000133	0.00136	0.001333	0.019337	1

TO CONVERT TO







www.leakproofseals.com



SINCE 1973

Leak-Proof

Engineering (I) Pvt. Ltd.

HEAD OFFICE

Leak-Proof House, Pushtikar C.H.S. Ltd
Patel Estate Road, Opp. Amboli Police Station
Jogeshwari (West), Mumbai - 400 102, India
Phone: +91 22 2679 7771, 7773
E-mail: ho@leakproofseals.com

MANUFACTURING UNIT

Block A, B & C, EDR Industrial Estate
Chhapi - Pirojpura Road, Pirojpura, Vadgam
Banaskantha, Gujarat - 385 210, India.
Fax: +91 2739 270052
Phone: +91 2739 270151, 270152
E-mail: mfg@leakproofseals.com